

# INSTALLER INSTRUCTIONS

## CONTENTS

1	DESCRIPTION OF THE BOILER .....	66
2	INSTALLATION .....	71
3	CHARACTERISTICS .....	78
4	USE AND MAINTENANCE .....	78

## IMPORTANT

When carrying out commissioning of the boiler, you are highly recommended to perform the following checks:

- Make sure that there are no liquids or inflammable materials in the immediate vicinity of the boiler.
- Make sure that the electrical connections have been made correctly and that the earth wire is connected to a good earthing system.
- Check that the flue pipe for the outlet of the products of the combustion is unobstructed.
- Make sure that any shutoff valves are open.
- Make sure that the system is charged with water and is thoroughly vented.
- Check that the circulator is not blocked.

# 1 DESCRIPTION OF THE BOILER

## 1.1 INTRODUCTION

One of the features of the cast iron thermal group with the integrated gas-oil burner is its functional silence and it has been designed in accordance with the European directives CEE 92/42. The perfectly balanced combustion

and the high yield allows it to economise considerably the operating costs. The instructions relative to the following models are indicated in the present manual:

- "AQUA 30-40 OF" for heating and hot water production with accumulative tank.

- "AQUA 30-40 BF" for heating and hot water production with accumulative tank and airtight combustion burner.

The instructions given in this manual are provided to ensure proper installation and perfect operation of the appliance and should be strictly followed.

## 1.2 DIMENSIONS

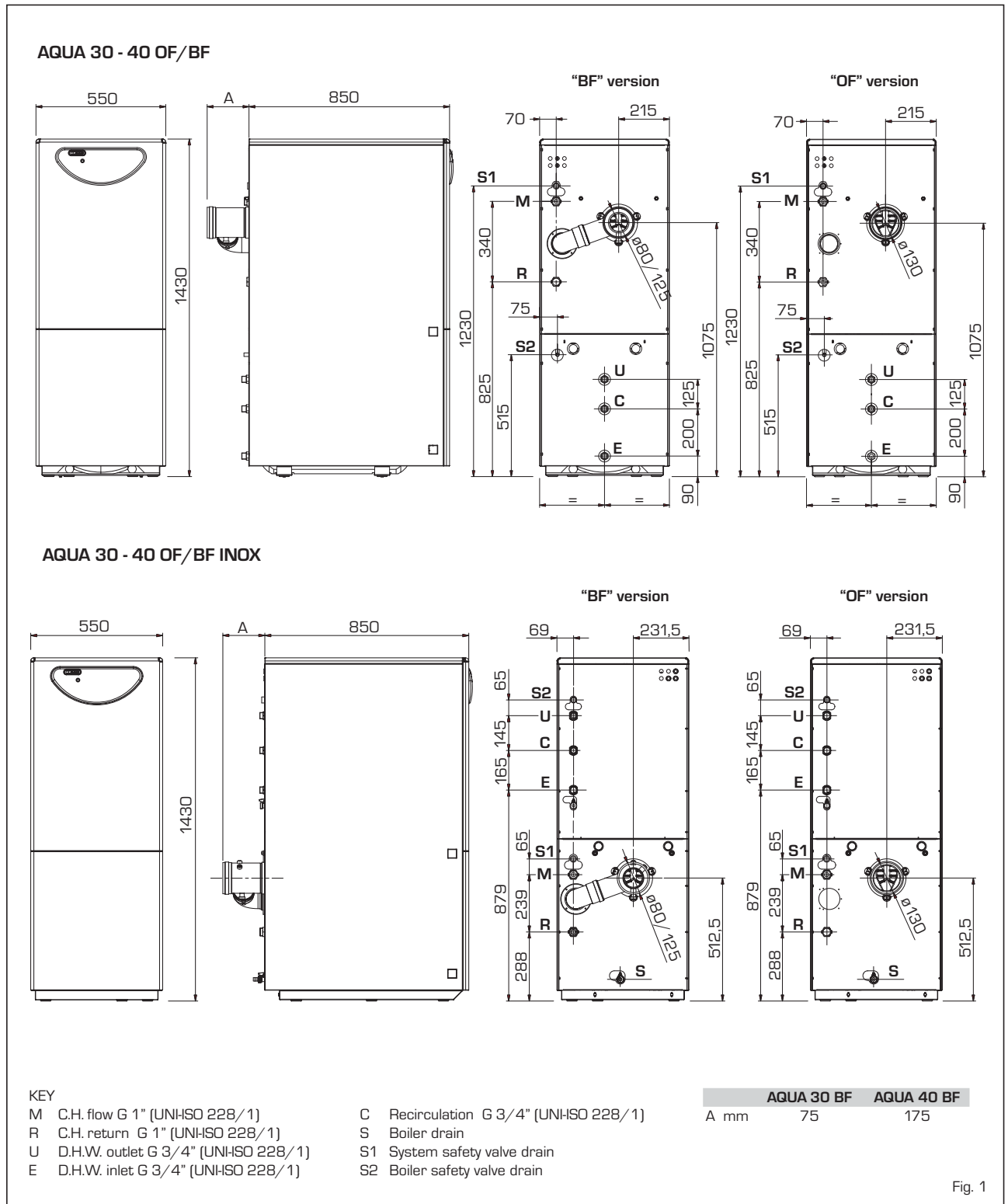

Fig. 1

### 1.3 TECHNICAL FEATURES

		AGUA 30 OF/BF	AGUA 40 OF/BF	AGUA 30 OF/BF INOX	AGUA 40 OF/BF INOX
<b>Heat output *</b>	kW	31.3 (27.5)	40.0 (35.2)	31.3 (27.5)	40.0 (35.2)
	kcal/h	26,900 (23,700)	34,400 (30,300)	26,900 (23,700)	34,400 (30,300)
<b>Heat input *</b>	kW	34.8 (30.6)	44.3 (39.0)	34.8 (30.6)	44.3 (39.0)
	kcal/h	29,900 (26,300)	38,100 (33,500)	29,900 (26,300)	38,100 (33,500)
<b>Type</b>		B23	B23	B23	B23
<b>Elements</b>	n°	4	5	4	5
<b>Maximum water head</b>	bar	4	4	4	4
<b>Water content</b>	l	28	33	24.5	30.5
<b>Expansion vessel</b>					
Water content/Preloading pressure	l/bar	10/1	12/1	10/1	12/1
<b>Loss of head smoke</b>	mbar	0.16	0.21	0.16	0.21
<b>Combustion chamber pressure **</b>	mbar	- 0.02	- 0.05	- 0.02	- 0.05
<b>Suggested chimney depression **</b>	mbar	0.18	0.23	0.18	0.23
<b>Smoke temperature</b>	°C	185	185	185	185
<b>Smoke flow *</b>	m³/h	41.4 (35.9)	52.8 (46.3)	41.4 (35.9)	52.8 (46.3)
<b>CO<sub>2</sub></b>	%	12.5	12.5	12.5	12.5
<b>Maximum temperature</b>	°C	95	95	95	95
<b>Power consumption "OF/BF"</b>	W	200/230	180/210	200/230	180/210
<b>Adjustment range heating</b>	°C	45÷85	45÷85	45÷85	45÷85
<b>Adjustment range D.H.W.</b>	°C	30÷60	30÷60	30÷60	30÷60
<b>D.H.W. production</b>					
Tank capacity	l	120	120	110	110
D.H.W. flow rate EN 625	l/min	20.9	20.9	20.9	20.9
Contin. D.H.W. flow rate Δt 30°C *	l/h	840 (790)	840	830 (780)	830
D.H.W. expansion vessel	l	4	4	4	4
D.H.W. tank maximum water head	bar	7	7	7	7
<b>Gas-oil burner ***</b>					
<b>Burner nozzle *</b>		0.75 60°W	0.85 60°W	0.75 60°W	0.85 60°W
		(0.65 60°W)	(0.85 60°W)	(0.65 60°W)	(0.85 60°W)
<b>Pump pressure *</b>	bar	14 (14)	14 (12)	14 (14)	14 (12)
<b>Shutter regulator position for "OF" version *</b>		5.2 (4.1)	6.2 (5.3)	5.2 (4.1)	6.2 (5.3)
<b>Shutter regulator position for "BF" version *</b>		4.1 (4.0)	3.6 (2.4)	4.1 (4.0)	3.6 (2.4)
<b>Diaphragm position for "BF" version *</b>		G (D)	-	G (D)	-
<b>Weight</b>	kg	226	254	220	247

\* The data shown between the brackets refer to the factory settings

\*\* For "OF" versions only

\*\*\* Calibration values with the coaxial drain terminal code 8096220 installed

## 1.4 MAIN COMPONENTS

### 1.4.1 "AQUA 30-40 OF/BF" version

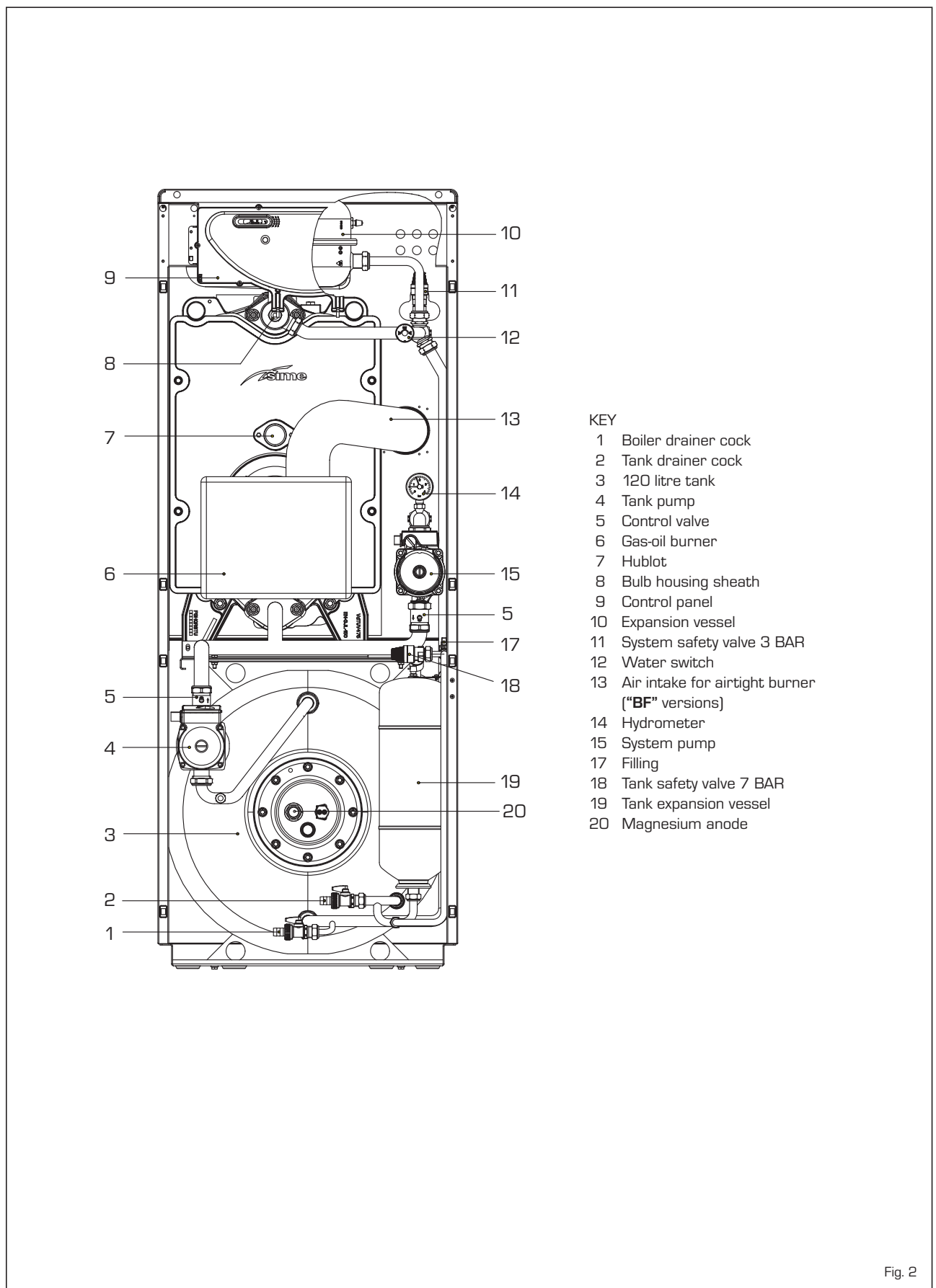
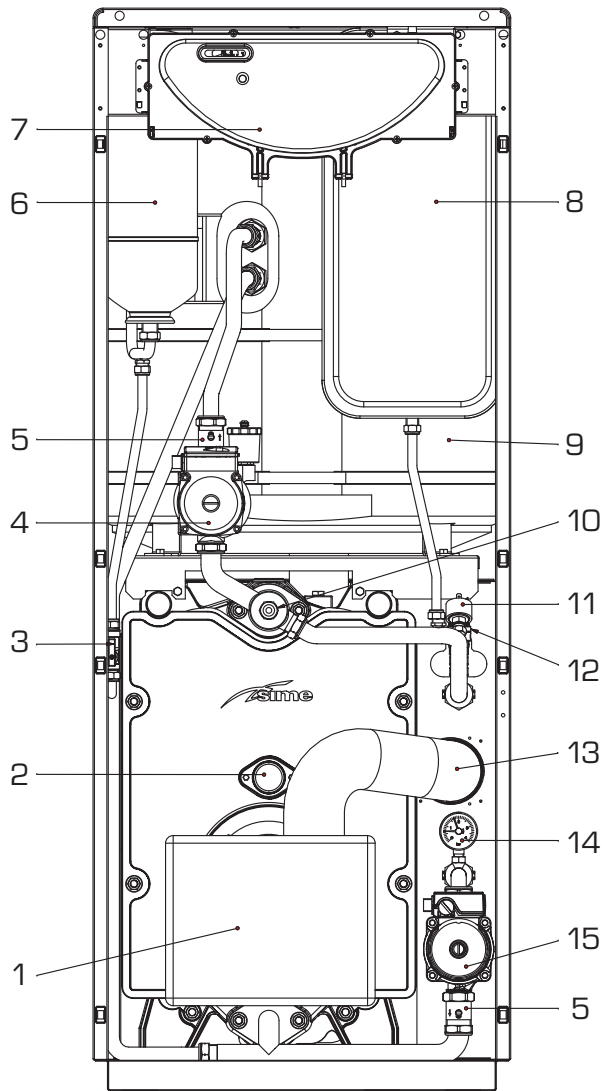

Fig. 2

1.4.2 "AQUA 30-40 OF/BF INOX" version



KEY

- 1 Gas-oil burner
- 2 Hublot
- 3 Filling
- 4 Tank pump
- 5 Control valve
- 6 Tank expansion vessel
- 7 Control panel
- 8 Expansion vessel
- 9 110 litre tank in inox
- 10 Bulb housing sheath
- 11 Water switch
- 12 System safety valve 3 BAR
- 13 Air intake for airtight burner ("BF" versions)
- 14 Hydrometer
- 15 System pump
- 16 Magnesium anode

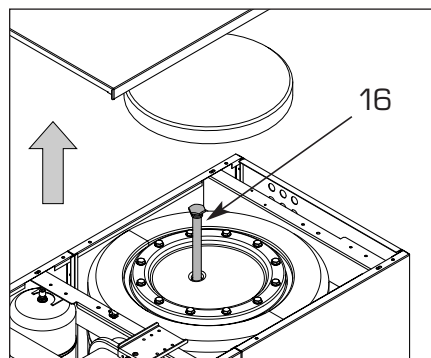
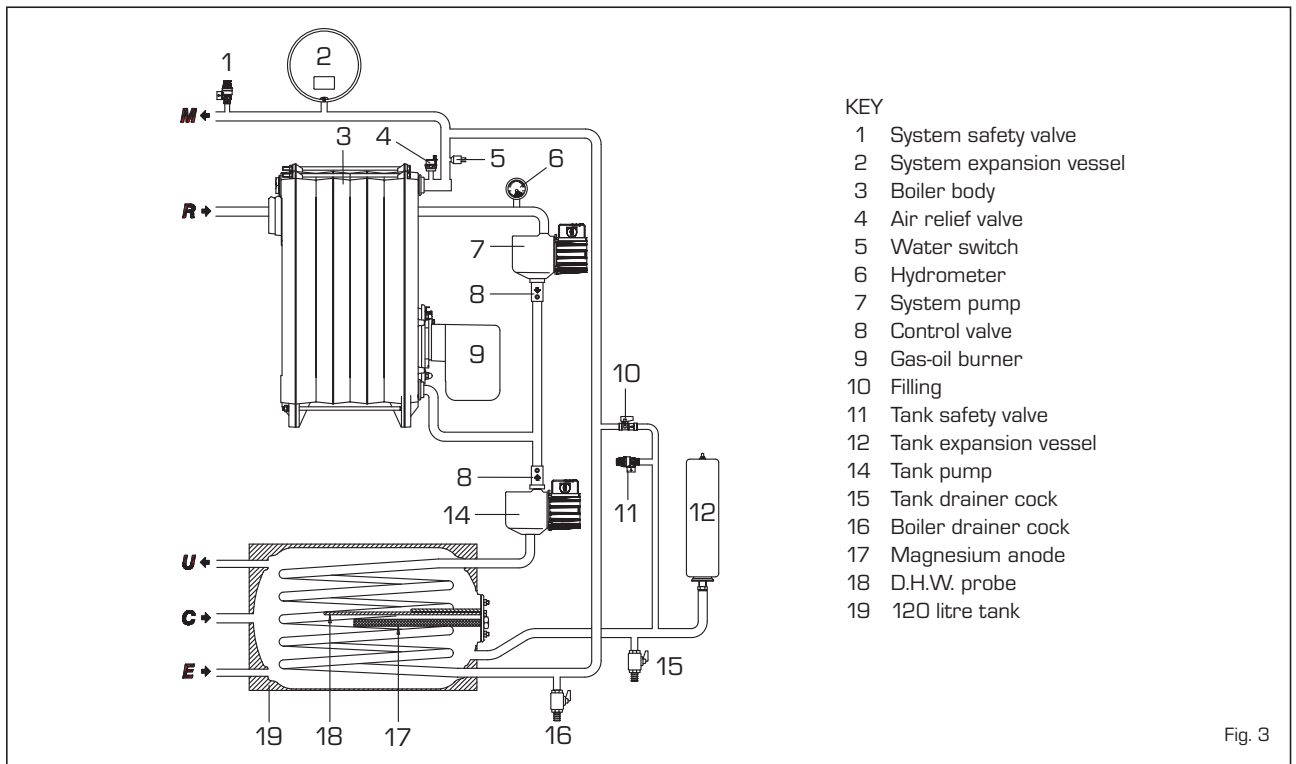

Fig. 2/a

## 1.5 FUNCTIONAL DIAGRAM

### 1.5.1 "AQUA 30-40 OF/Bf" version



### 1.5.2 "AQUA 30-40 OF/BF INOX" version

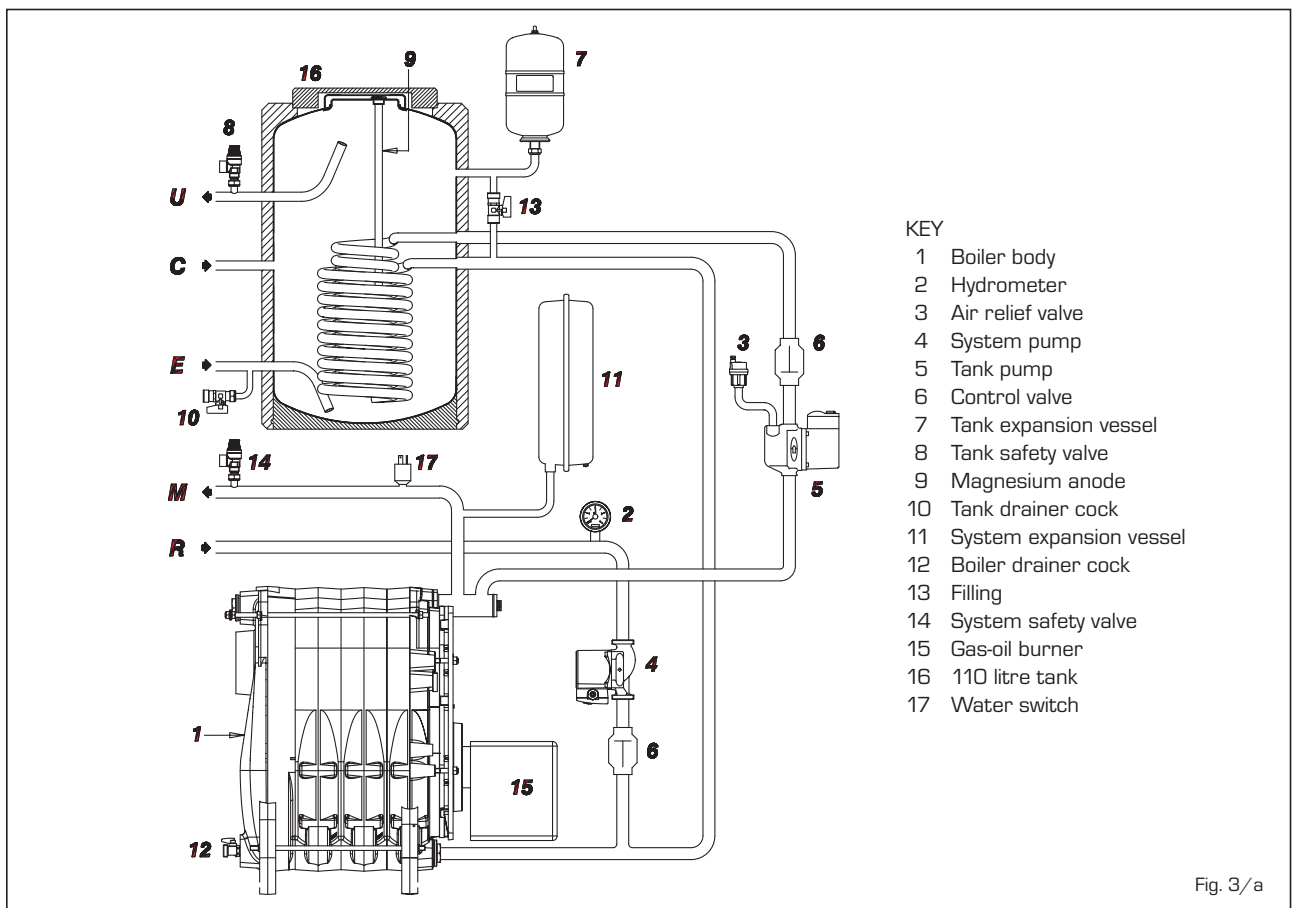

## 2 INSTALLATION

### 2.1 BOILER ROOM

The boilers with a rating of more than 35 kW must be equipped with a technical room whose dimensions and requirements correspond to the current standards and regulations.

The minimum distance between the walls of the room and the boiler must not be less than 0.60 m., while the minimum height between the top of the boiler and the ceiling must be at least 1 m. which can be reduced to 0.50 m. for boilers with incorporated heaters (however the minimum height of the boiler room must not be less than 2,5 m). The boilers with a rating of less than 35 kW can be installed only in perfectly air-vented rooms.

To circulate air in the room, air vents must be made on the outside walls which satisfy the following requirements:

- Have a total surface area of at least 6 cm<sup>2</sup> for each installed Kw of thermal capacity and however not less than 100 cm<sup>2</sup>.
- To be situated as close as possible to the floor; unobstructable and protected by a grate which does not reduce the air passage area.

### 2.2 CONNECTING UP SYSTEM

Before proceeding to connect up the boiler, you are recommended to make the water circulate in the piping in order to eliminate any foreign bodies that might be detrimental to the operating efficiency of the appliance.

For connecting up the pipes, make sure to follow the indications illustrated in fig. 1.

The connections should be easy to disconnect using pipe unions with orientable connections.

**The shutoff valve must be connected to a suitable flow system and return pipes.**

#### 2.2.1 System filling

The boiler and the relative system must be filled operating on the bearing tap and the pressure of cold charging the system must be included between **1 - 1.2 bar**. During filling the main switch should be left open.

Filling must be done slowly so as to allow any air bubbles to be bled off through the provided air vents.

This operation can be made easy by positioning horizontally the incision of

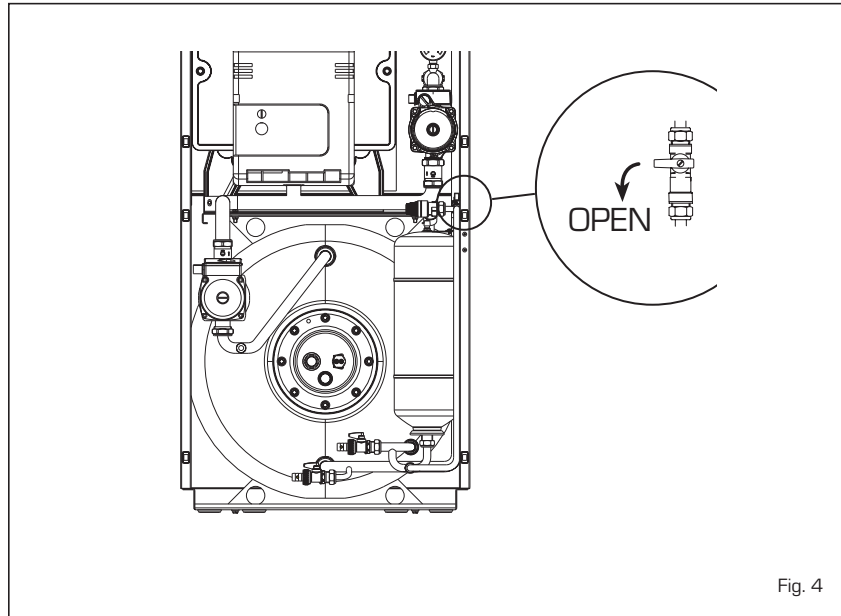

Fig. 4

the block screw of the shutoff valve. Upon completing the filling, put the screw back to its original position. At the end of the operation make sure that the tap is closed (fig. 4).

#### 2.2.2 D.H.W. production

In order that the boiler be capable of supplying treated water, all the air in the boiler's serpentine must be bled off at the first ignition. This operation is made easy by positioning horizontally the incision of the block screw of the shutoff valve (5 fig. 2-2/a). After all the air has been bled off, put the screw back to its original position.

#### 2.2.3 Characteristics of feedwater

To prevent lime scale and damage to the tap water exchanger, the water supplied should have a hardness of no more than 20°F.

In all cases the water used should be tested and adequate treatment devices should be installed.

To prevent lime scale or deposits on the primary exchanger, the water used to supply the heating circuit should must be treated in accordance with UNI-CTI 8065 standards. It is absolutely essential that the water is to be treated in the following cases:

- Very extensive systems (with high contents of feedwater).
- Frequent addition of makeup water into the system.
- In case it is necessary to empty the system either partially or totally.

### 2.3 SMOKE EXHAUST

#### 2.3.1 Connecting up flue

The flue is of fundamental importance for the proper operation of the boiler; if not installed in compliance with the standards, starting the boiler will be difficult and there will be a consequent formation of soot, condensation and encrustation.

A flue therefore must satisfy the following requirements:

- be constructed with waterproof materials and resistant to smoke temperature and condensate;
- be of adequate mechanical resilience and of low heat conductivity;
- be perfectly sealed to prevent cooling of the flue itself;
- be as vertical as possible; the terminal section of the flue must be fitted with a static exhaust device that ensures constant and efficient extraction of products generated by combustion;
- to prevent the wind from creating pressure zones around the chimney top greater than the uplift force of combustion gases, the exhaust outlet should be at least 0.4 m higher than structures adjacent to the stack (including the roof top) within 8 m;
- have a diameter that is not inferior to that of the boiler union: square or rectangular-section flues should have an internal section 10% greater than that of the boiler union;
- the useful section of the flue must conform to the following formula:

$$S = K \frac{P}{\sqrt{H}}$$

- S resulting section in cm<sup>2</sup>
- K reduction coefficient for liquid fuels: 0.024
- P boiler input in Kcal/h
- H height of the flue in meters measured from the flame axis to the flue outlet into the atmosphere. When dimensioning the flue, the effective height of the flue in meters must be considered, measured from the flame axis to the top of the flue, reduced by:
  - 0.50 m for each change of direction of the connection union between boiler and flue;

- 1.00 for each horizontal metre of the union itself.

Our boilers are the B23 type and do not need any particular connections other than the one to the flue as described above.

### 2.3.2 Smoke exhaust with ø 80/125 coaxial flue

“BF” version boilers are set to be connected to ø 80/125 stainless steel coaxial flues that can be adjusted to the most suitable direction for room requirements (fig. 6).

The maximum acceptable length of

the flue must not be over 7.0 equivalent meters.

Load losses in meters for each single accessory to be used in the exhaust configuration are indicated in Table A.

Only use original SIME accessories and make sure that connections are correct as indicated in the instructions supplied with the accessories.

### 2.4 FUEL ADDUCTION

The fuel can be fed into the thermal group sideways, the ducts must be passed through the aperture on the

#### KEY

- 1 Stainless steel coaxial flue L. 886 code 8096220
- 2a Stainless steel extension L. 1000 code 8096121
- 2b Stainless steel extension L. 500 code 8096120
- 3a 90° stainless steel curve MF code 8095820
- 3b 45° stainless steel curve MF code 8095920
- 4 Stainless steel vertical condensation recovery L. 135 code 8092820
- 5 Tile with hinge code 8091300
- 6 Roof outlet terminal L. 1063 code 8091203
- 7 Kit code 8098810

TABLE A

	Load loss (mt)
90° stainless steel curve MF	1,80
45° stainless steel curve MF	0,90
Stainless steel extension L. 1000	1,00
Stainless steel extension L. 500	0,50
Roof outlet terminal L. 1063	1,00
Stainless steel coaxial flue L. 886	0,70
Stainless steel vertical condensation recovery L. 135	0,70

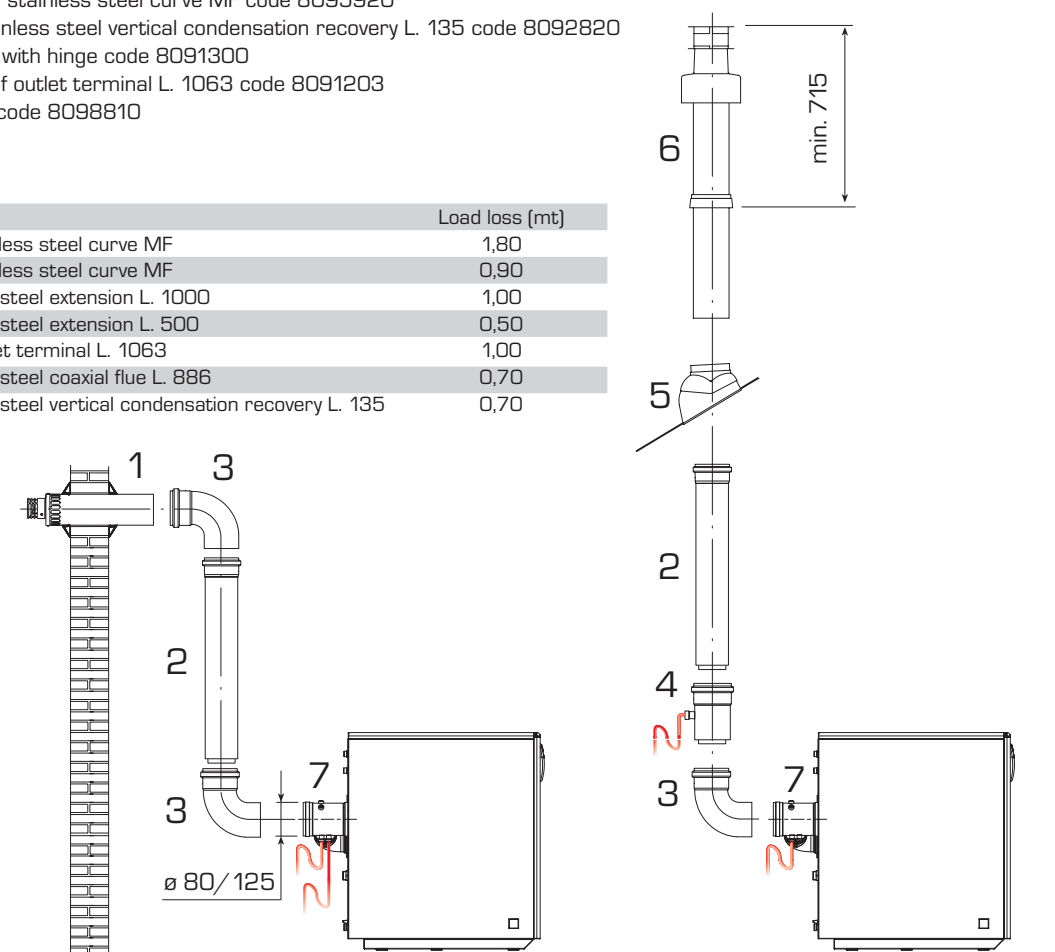

#### WARNING:

The maximum acceptable length of the flue must not be over 7.0 equivalent meters. Always use the condensation recovery (4) in outlets with vertical exhaust.

Fig. 6

right or left hand side of the shell for connection to the pump (fig. 7 - 7/a).

### Important

- Make sure, before turning on the boiler, that the return tube is free. An excessive counter-pressure would break the pump seal.
- Make sure that the tubes are sealed.
- The maximum depression of 0.4 bar (300 mmHg) [see Table 1] must not be exceeded. Gas is freed from the fuel above that value and can cause cavitation of the pump.
- It's advisable to bring the return tube in the depression systems up to the same height of the intake tube. In this case the foot valve is unnecessary. If instead the return tube arrives above the fuel level, the foot valve is indispensable.

### Starting the pump

Turn on the burner to start the pump and check the flame ignition. If a "lock out" occurs before fuel arrival, wait for at least 20 seconds then press the burner release button "RESET" and wait for the whole start-up operation to repeat until the flame lights up.

## 2.5 BURNER ADJUSTMENTS

Each unit is shipped with a burner unit equipped with a nozzle and calibrated at the factory; it is recommended, however, that the settings listed under point 1.3 be checked, with reference to atmospheric pressure at sea level. If it is necessary to adjust the burner differently from the factory settings, this should be done by authorised personnel following the instructions provided below.

Remove the shell door to access the burner unit's controls.

### 2.5.1 Air lock adjustment

To adjust the air lock, loosen the screw (1 fig. 8) and slide the graduated scale (2 fig. 8) indicating the position air lock position.

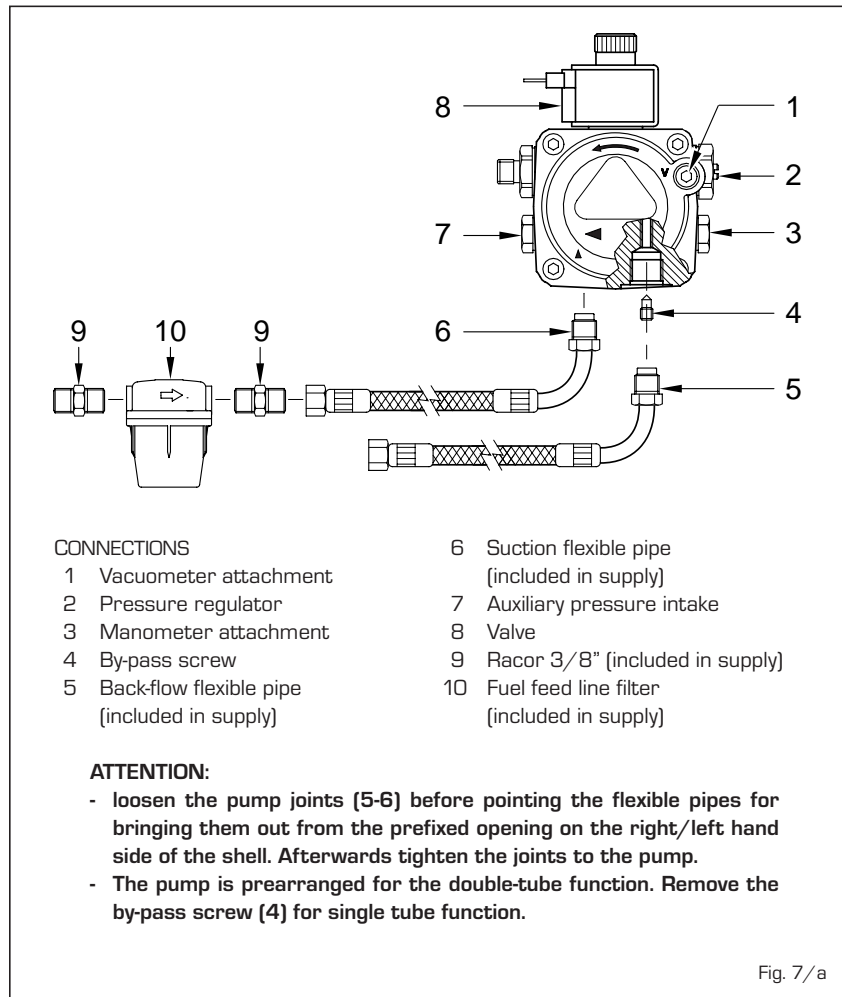
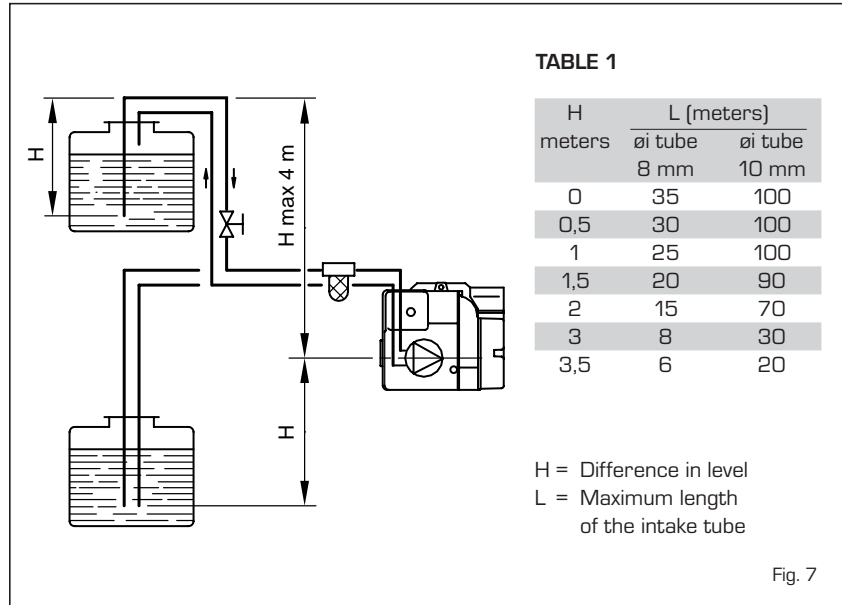

The values for adjustment of each unit are given in point 1.3.

### 2.5.2 Pump pressure adjustment

To adjust gas-oil pressure, turn the

screw (3 fig. 8/a) and check pressure with a pressure gauge connected to the intake (2 fig. 8/a), making sure pressure corresponds to the value given under point 1.3.

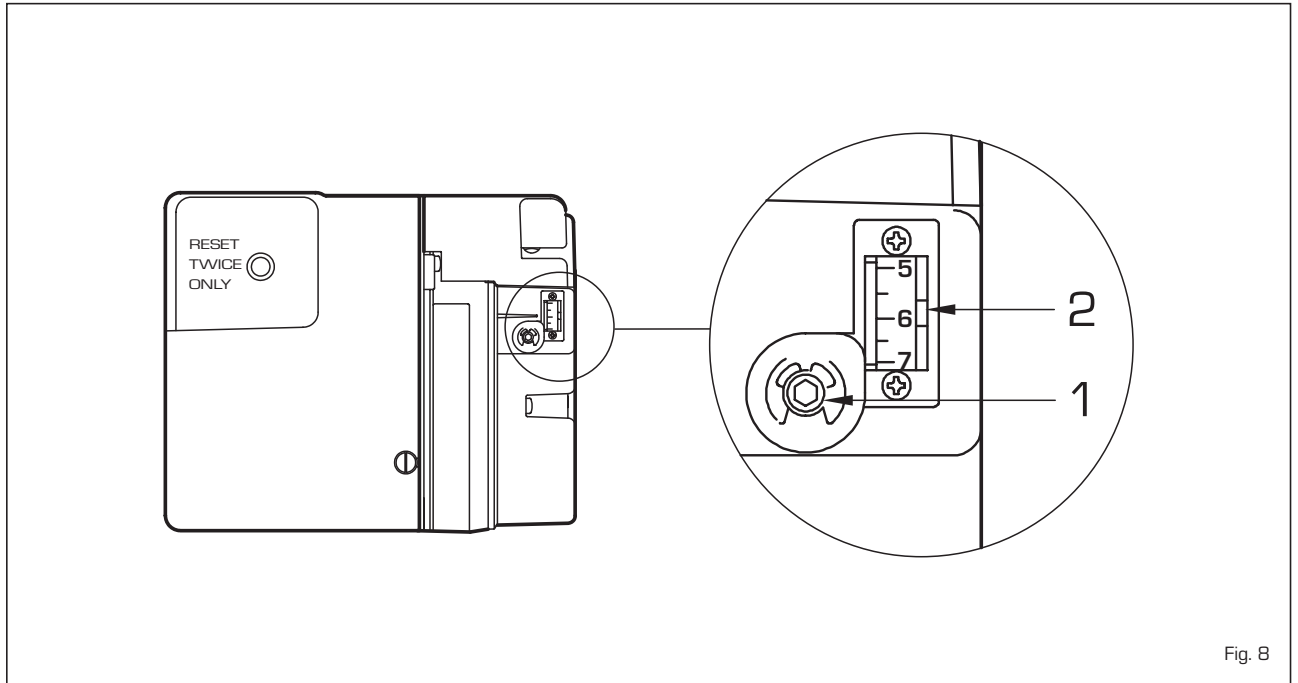

Fig. 8

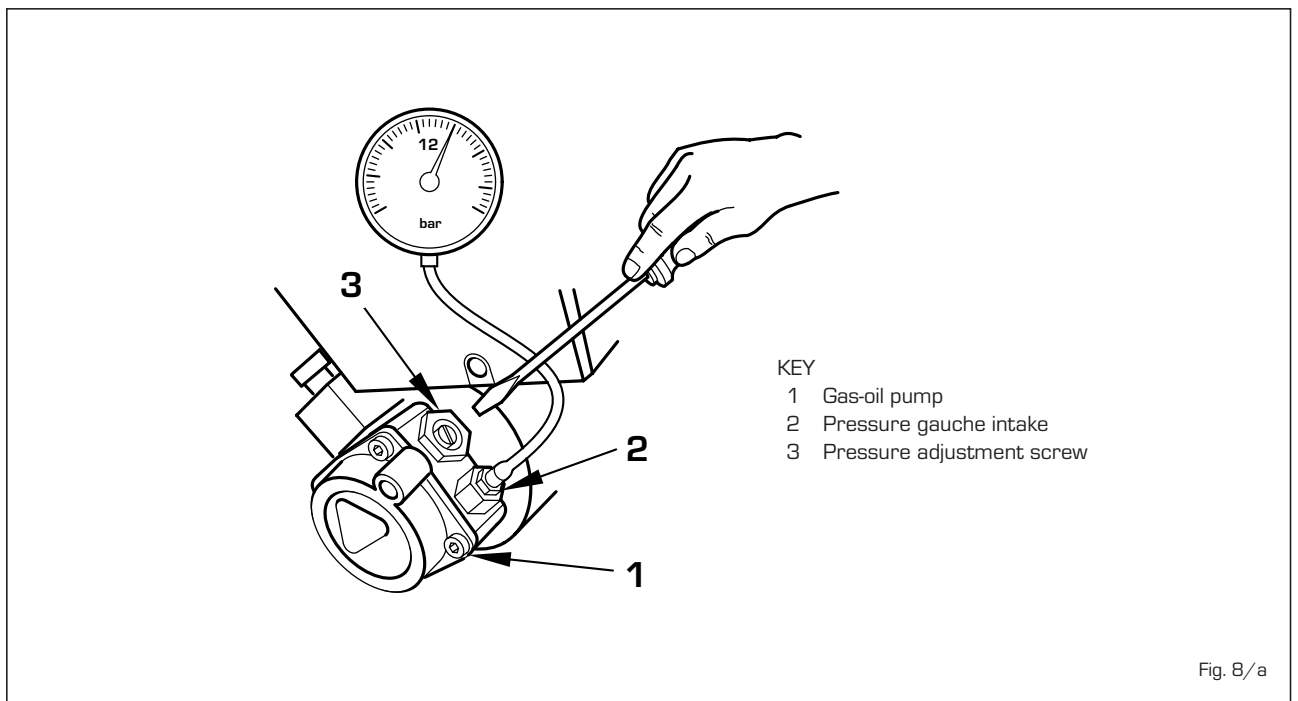

Fig. 8/a

## 2.6 HEATER UNIT

In "AQUA 30 OF/BF" and "AQUA 30 OF/BF INOX" models, the heater unit comes on with the consensus of the burner, after a delay of a maximum of 90 seconds required to bring fuel in the nozzle holder area up to a temperature of 65°C.

Once this temperature has been reached, the thermostat, which is located above the preheater (1 fig. 14/b), will give consensus for the burner to start. The heater will remain on for as long as the burner stays on

and go off when the burner goes off.

**NOTE:** "AQUA 40 OF/BF" and "AQUA 40 OF/BF INOX" model have no heater unit, as it is not required.

## 2.7 ELECTRICAL CONNECTION

The boiler is supplied with an electric cable and the electric power supply to the boiler must be 230V-50Hz single-phase through a fused main switch. The stat cable, whose installation is compulsory for obtaining a better

adjustment of the room temperature, must be connected as shown in fig. 9-9/a.

### **NOTE:**

**Device must be connected to an efficient earthing system. SIME declines all responsibility for injury or damage to persons resulting from the failure to provide for proper earthing of the appliance.**

**Always turn off the power supply before doing any work on the electrical panel.**

2.7.1 "AQUA OF/BF - AQUA OF/BF INOX" wiring diagram

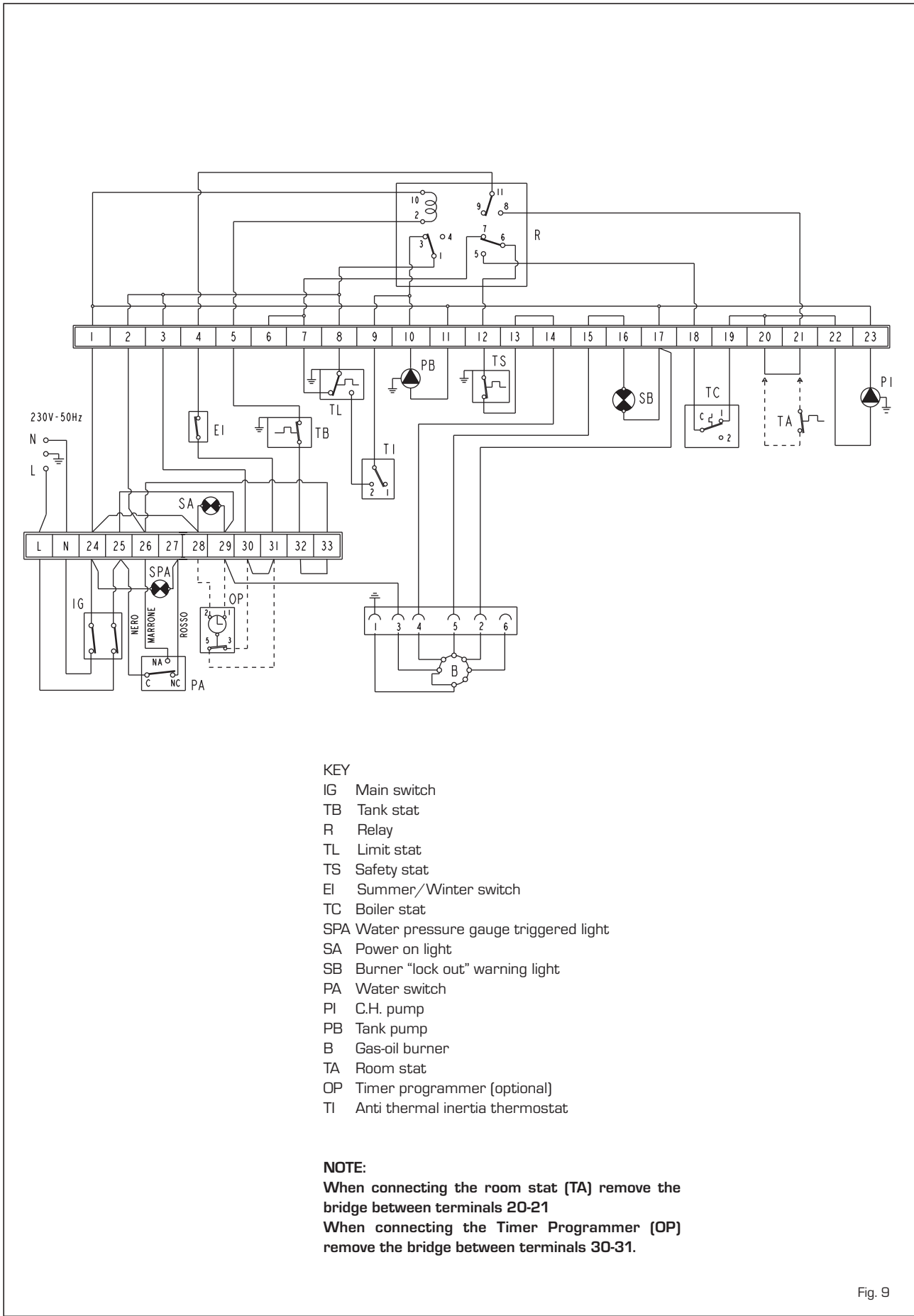

- KEY
- IG Main switch
  - TB Tank stat
  - R Relay
  - TL Limit stat
  - TS Safety stat
  - EI Summer/Winter switch
  - TC Boiler stat
  - SPA Water pressure gauge triggered light
  - SA Power on light
  - SB Burner "lock out" warning light
  - PA Water switch
  - PI C.H. pump
  - PB Tank pump
  - B Gas-oil burner
  - TA Room stat
  - OP Timer programmer (optional)
  - TI Anti thermal inertia thermostat

**NOTE:**  
 When connecting the room stat (TA) remove the bridge between terminals 20-21  
 When connecting the Timer Programmer (OP) remove the bridge between terminals 30-31.

Fig. 9

2.7.2 "AQUA OF/BF - AQUA OF/BF INOX" wiring diagram with optional RVA 43.222 unit

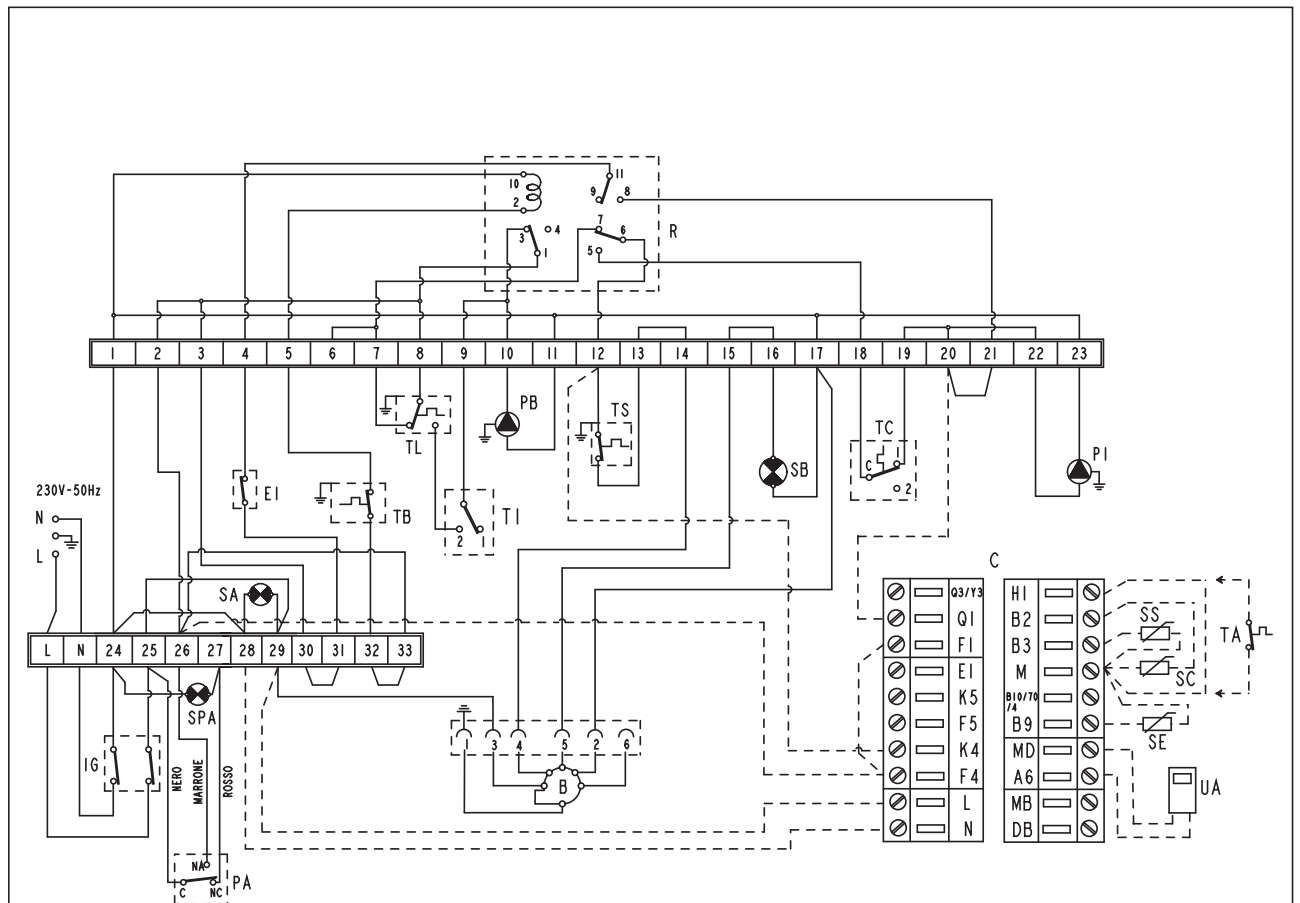

- KEY
- IG Main switch
  - TB Tank stat
  - R Relay
  - TL Limit stat
  - TS Safety stat
  - EI Summer/Winter switch
  - TC Boiler stat
  - SPA Water pressure gauge triggered light
  - SA Power on light
  - SB Burner "lock out" warning light
  - PA Water switch
  - PI C.H. pump
  - PB Tank pump
  - B Gas-oil burner
  - TA Room stat
  - C RVA 43.222 control unit connectors (optional)
  - SS Type QAZ21 boiler immersion probe (optional)
  - SC Type QAZ21 boiler immersion probe (optional)
  - SE Outdoor temperature probe QAC31 (optional)
  - UA Type QAA70 room thermometer (optional)
  - TI Anti thermal inertia thermostat

**NOTE:** When connecting the RV 43 222 unit remove the bridge between terminals 20-21 and remove the relay (R).

Fig. 9/a

2.7.3 "AQUA 30 OF/BF - AQUA 30 OF/BF INOX" functional diagram

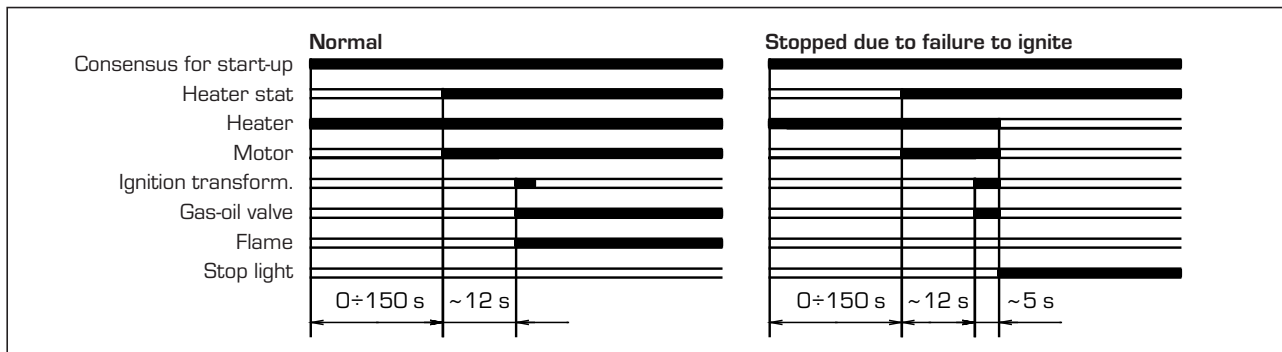

2.7.4 "AQUA 40 OF/BF - AQUA 40 OF/BF INOX" functional diagram

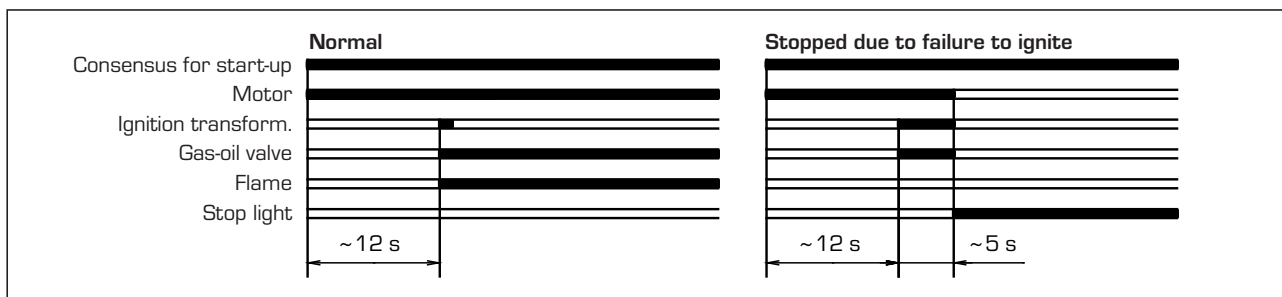

## 3 CHARACTERISTICS

### 3.1 COMBUSTION CHAMBER DIMENSIONS

The combustion chamber is a direct passage type and is conform to the EN 303-3 standard annex E. The dimensions are shown in fig. 10. An adequate protection panel is mounted on the inside wall of the rear head of all the models.

	L	Volume
	mm	dm <sup>3</sup>
<b>AQUA 30</b>	405	24,0
<b>AQUA 40</b>	505	30,5

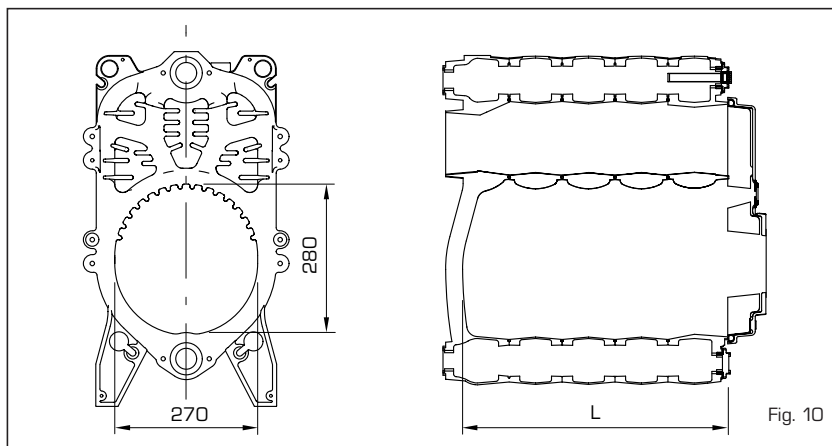

Fig. 10

### 3.2 SYSTEM AVAILABLE HEAD

The head available for the heating plant is shown as a function of the flow in graph in fig. 11.

### 3.3 ANTI THERMAL INERTIA THERMOSTAT

The purpose of the anti thermal inertia thermostat (TI) is to restart the boiling unit pump when the boiler reaches the temperature of 90°C, discharging the excess heat due to the thermal inertia of the cast iron body towards the boiling unit. The circulator will automatically stop working as soon as the boiler temperature falls below 90°C.

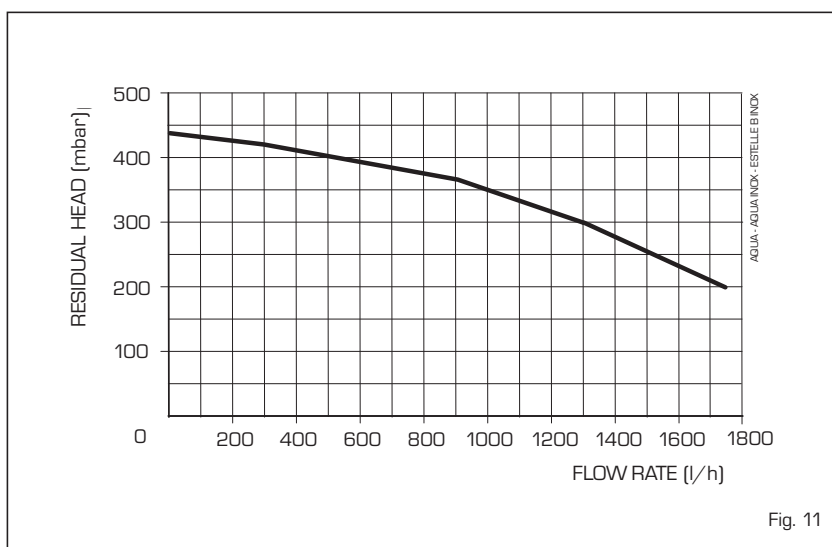

Fig. 11

## 4 USE AND MAINTENANCE

### 4.1 RVA 43.222 UNIT (optional)

The control panel allows the use della centralina RVA 43.222 supplied in kit form upon request, complete with mounting instructions (fig. 12). Make the electric connection as

shown in point 2.7.

### 4.2 TANK MAINTENANCE

The preparation of hot treated water is guaranteed by a heater in INOX AISI 316L, complete with magnesium

anode for protecting the heater and inspection flange for control and cleaning.

**The magnesium anode (20 fig. 2 - 16 fig. 2/a) should be periodically controlled and substituted whenever worn out.**

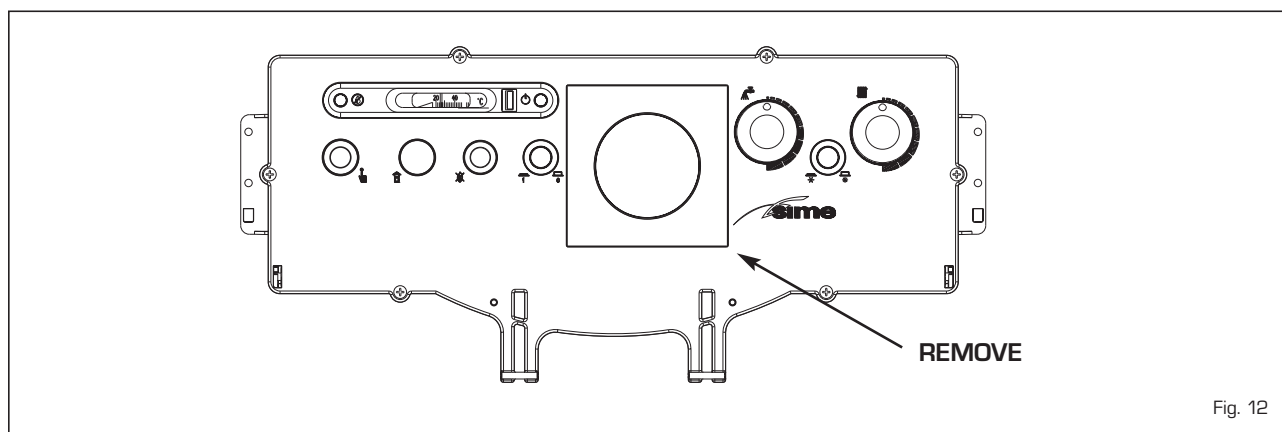

Fig. 12

#### 4.4 DISASSEMBLY OF OUTER CASING

The shell can be completely disassembled for an easy maintenance of the boiler by following the numeric steps shown in fig. 13.

#### 4.5 DISASSEMBLY OF EXPANSION VESSEL

The heating expansion tank is disassembled in the following manner:

- Make sure that the boiler has been emptied of water.

- Unscrew the union which connects the expansion tank.
- Remove the expansion tank.

Before filling up the system make sure that the expansion tank is reloaded at the pressure of  $0.8 \div 1$  bar.

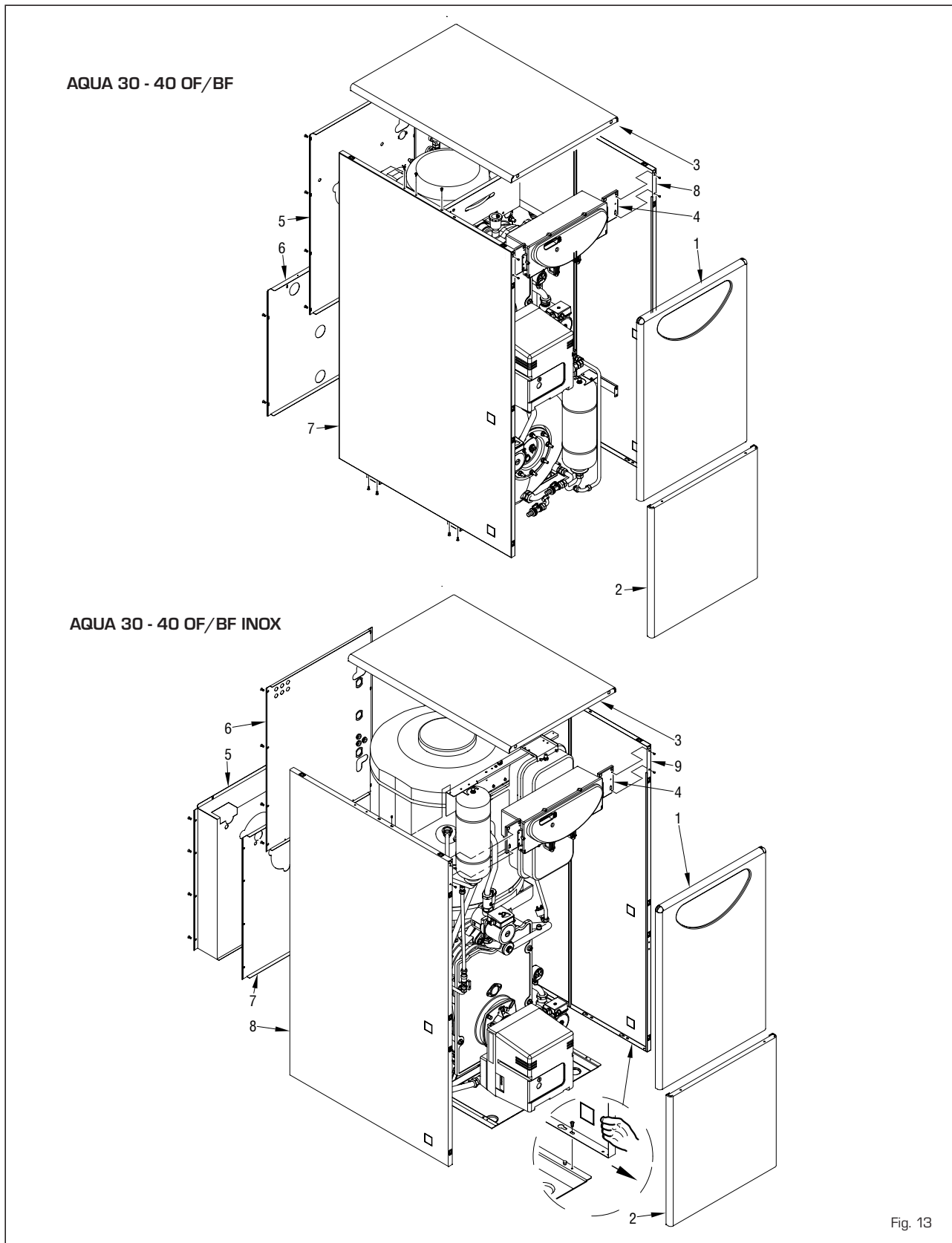

Fig. 13

## 4.6 BURNER MAINTENANCE

To dismantle the burner from the boiler door, remove the nut (fig. 14).

- To access the internal part of the burner, remove the air lock unit held in place by two screws to the sides and remove the right hand shell, which is held in place by four screws, taking care not to damage the O-ring seal. OR.
- To dismantle the nozzle holder and heater unit, proceed as follows:
  - open the cover, which is held in place by a screw, and remove the heater cables (1 fig. 14/a) protected by a heat resistant sheath; remove the fairlead and pass the cables through the hole.
  - remove the two cables from the ignition electrodes fastened in place with a faston.
  - loosen the union (2 fig. 14/a) and remove the four screws which fasten the collar (3 fig. 14/a) to the burner.
- To dismantle the eater or thermostat, refer to figure 14/b.

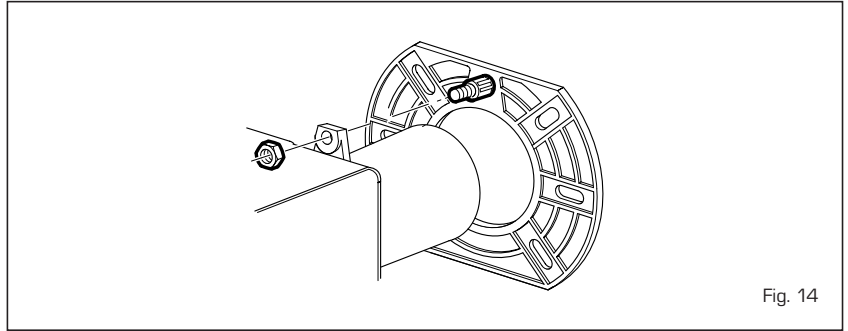

Fig. 14

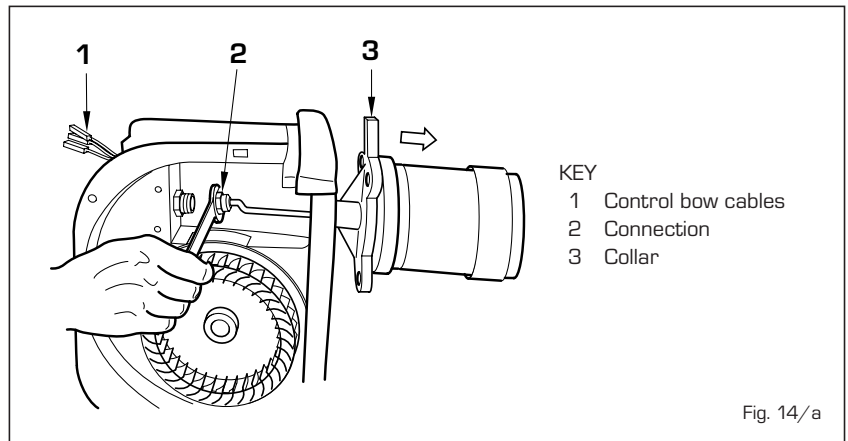

Fig. 14/a

## 4.7 CLEANING AND MAINTENANCE

Preventive maintenance and checking of the efficient operation of the equipment and safety devices must be carried out at the end of each heating season exclusively by the authorised technical staff.

### 4.7.1 Cleaning smoke ducts

Use an adequate swab for cleaning the smoke ducts of the boiler. After cleaning, position the circulators in their original position (fig. 15).

### 4.7.2 Cleaning combustion head

The combustion head is cleaned in the following manner (fig. 16):

- Disconnect the high tension cables from the electrodes.
- Unscrew the fixture screws of the circulator support and remove it.
- Brush the propeller delicately (turbulence disc).
- Carefully clean the photo-resistance of eventual deposits of dirt deposited on its surface.
- Clean the remaining components of the combustion head of eventual deposits.

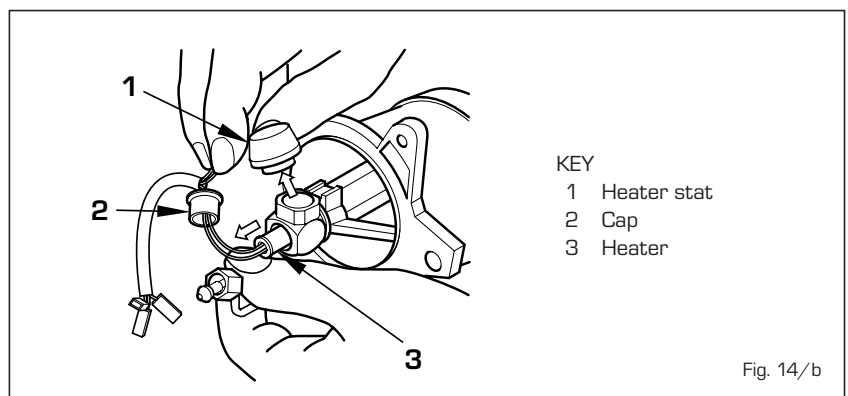

Fig. 14/b

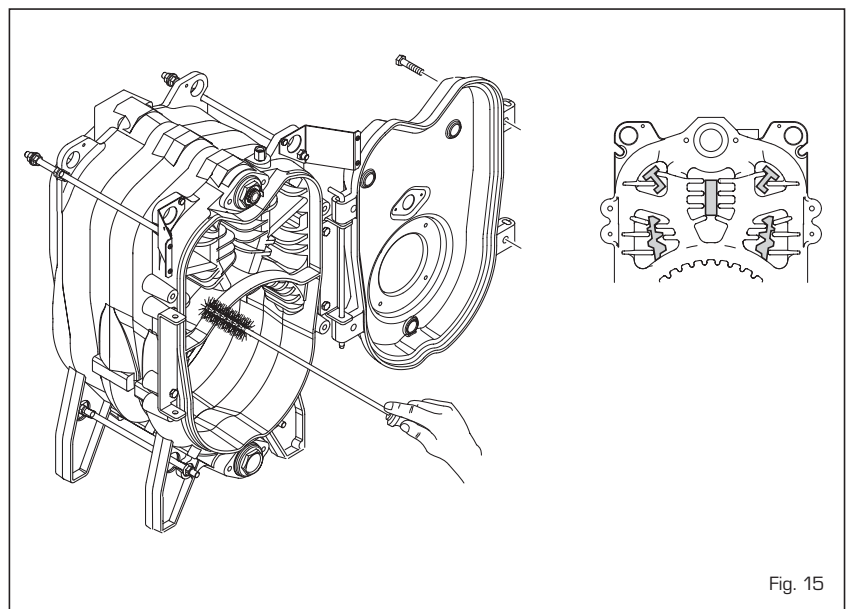

Fig. 15

- Upon completion re-assemble the unit in the opposite way as described above taking care to respect the indicated measurements.

#### 4.7.3 Substitution of nozzle

The nozzle should be substituted at the beginning of every heating system for guaranteeing the correct fuel flow and a good spray efficiency.

The nozzle is substituted in the following manner:

- Disconnect the high tension cables from the electrodes.
- Loosen the fixture screw [A fig. 16] of the electrodes support and remove it.
- Block the spray door using a n°19 spanner and unscrew the nozzle with a n°16 spanner [fig. 17].

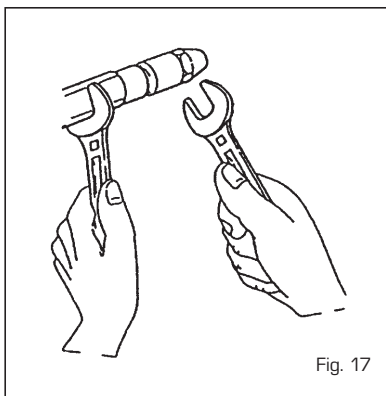

Fig. 17

#### 4.8 FAULT FINDING

There follow a list of some reasons and the possible remedies for a series of faults which could happen causing a failure or an irregular function of the appliance. A function fault, in most cases, causes the "lock out" signal on the control panel to turn on. When this light turns on, the burner can only function again after the reset button

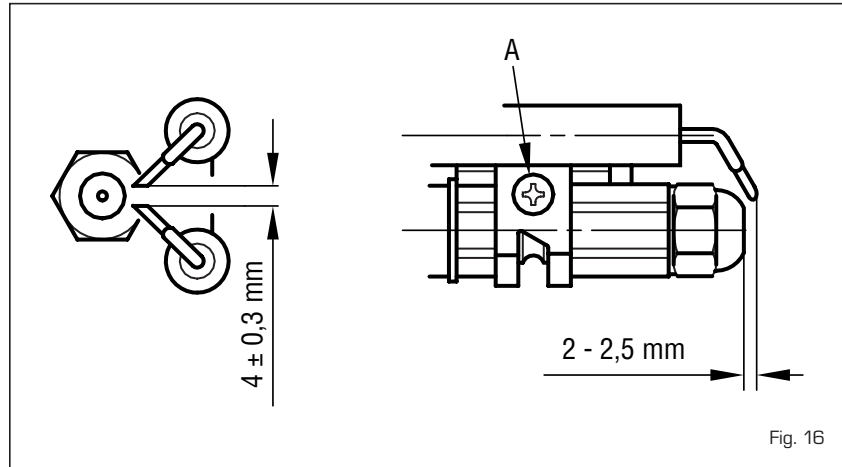

Fig. 16

has been pressed; once this has been done and a regular ignition occurs, the failure can be defined momentary and not dangerous.

On the contrary, if the "lock out" persists, then the cause of the fault as well as the remedy must be looked for in the following faults:

##### The burner does not ignite

- Check the electric connections.
- Check the regular fuel flow, the cleanness of the filters, of the nozzle and air vent from the tube.
- Check the regular spark ignition and the proper function of the burner.

##### The burner ignites regularly but the flame goes out immediately

- Check the flame detection, the air calibration and the function of the appliance.

##### Difficulty in regulating the burner and/or lack of yield

- Check: the regular flow of fuel, the cleanness of the boiler, the non obstruction of the smoke duct, the real input supplied by the burner and its cleanness (dust).

##### The boiler gets dirty easily

- Check the burner regulator (smoke analysis), the fuel quantity, the flue

obstruction and the cleanness of the air duct of the burner (dust).

##### The boiler does not heat up

- Control the cleanness of the shell, the matching, the adjustment, the burner performances, the pre-adjusted temperature, the correct function and position of the regulation stat.
- Make sure that the boiler is sufficiently powerful for the appliance.

##### Smell of unburnt products

- Control the cleanness of the boiler shell and the flue, the airtightness of the boiler and of the flue ducts (door, combustion chamber, smoke ducts, flue, washers).
- Control the quality of the fuel.

##### Frequent intervention of the boiler shutoff valve

- Control the presence of air in the system, the function of the circulation pumps.
- Check the load pressure of the appliance, the efficiency of the expansion tanks and the valve calibration.

# USER INSTRUCTIONS

## WARNINGS

- In case of fault and/or incorrect operation, deactivate it without making any repairs or taking any direct action. If fuel or combustion is smelt, air the room and close the fuel interception device. Contact the authorised technical staff.
- The installation of the boiler and any servicing or maintenance job must be carried out by qualified personnel.
- It is absolutely prohibited to block the intake grilles and the aeration opening of the room where the equipment is installed. The intake grilles are indispensable for a correct combustion.

## IGNITION AND OPERATION

### BOILER IGNITION

Press the main switch for lighting the boiler. The green light turns on to indicate that the appliance is powered (fig. 18).

Choose the position Summer/Winter on the switch (fig. 19):

- The boiler operates in treated phase with the switch in the position ☼ (SUMMER)

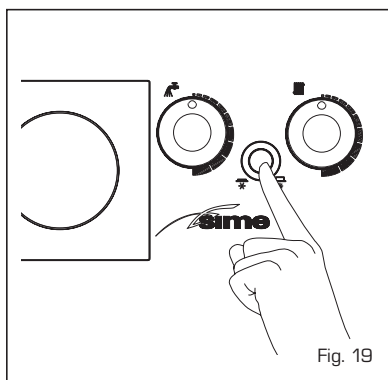
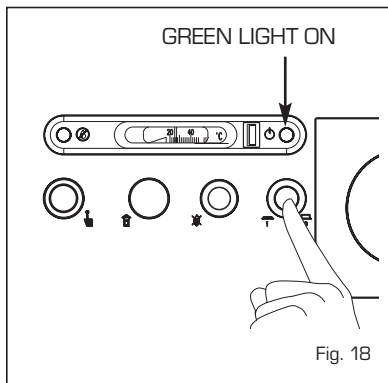

- The boiler operates both in treated phase as well as for heating with the switch in the position ❄️ (WINTER). The room stat or the chronostat will stop the operation of the boiler.

### TEMPERATURE ADJUSTMENT

- The heating temperature can be adjusted by turning the knob of the thermostat (fig. 20).
- The heating temperature can be adjusted by turning the knob of the thermostat which has a range of between 45 and 85°C. The temperature setting can be checked on the thermometer.

To ensure optimal boiler efficiency at all times, we recommend not to drop below a minimum working temperature of 60°C (fig. 21).

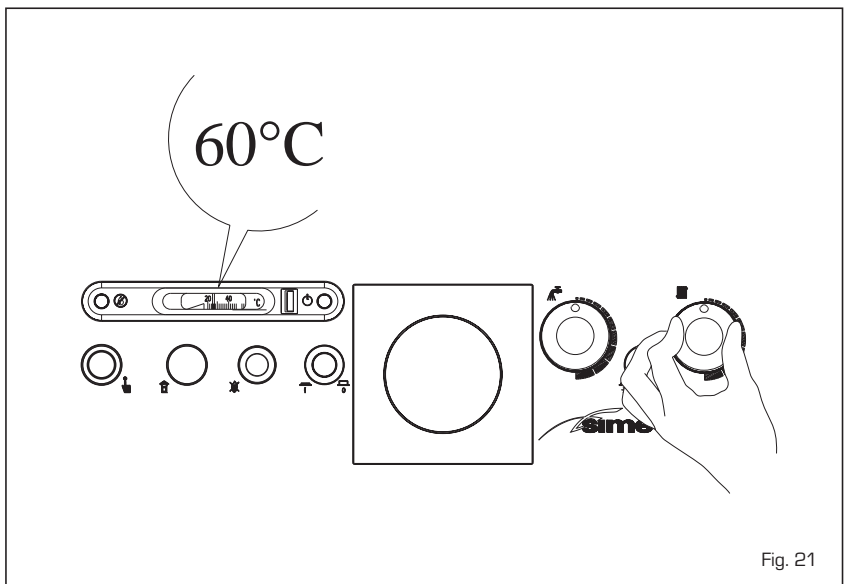
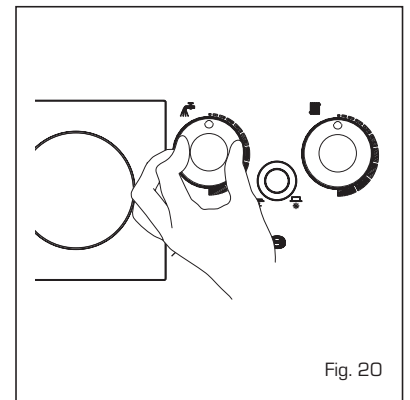

## SAFETY STAT

The safety stat is of the manually resetting type and opens, causing the main burner to turn off immediately, whenever the temperature of 110°C is exceeded in the boiler. To restore boiler operation, unscrew the black cap and reset the button (fig. 22).

**Should the appliance "lock out" again, please approach the authorised technical staff.**

## BURNER RESTART

In case that ignition or operation faults occur, the main burner "locks out" and the red lamp lights up on the control panel. Press the "RESET" button to restart the ignition conditions until the flame lights up (fig. 23).

This operation can be repeated 2-3 times at maximum and in case of failure contact the authorised technical staff.

**ATTENTION: Make sure that there is fuel in the tank and that the taps are open. After each fill up of the tank it**

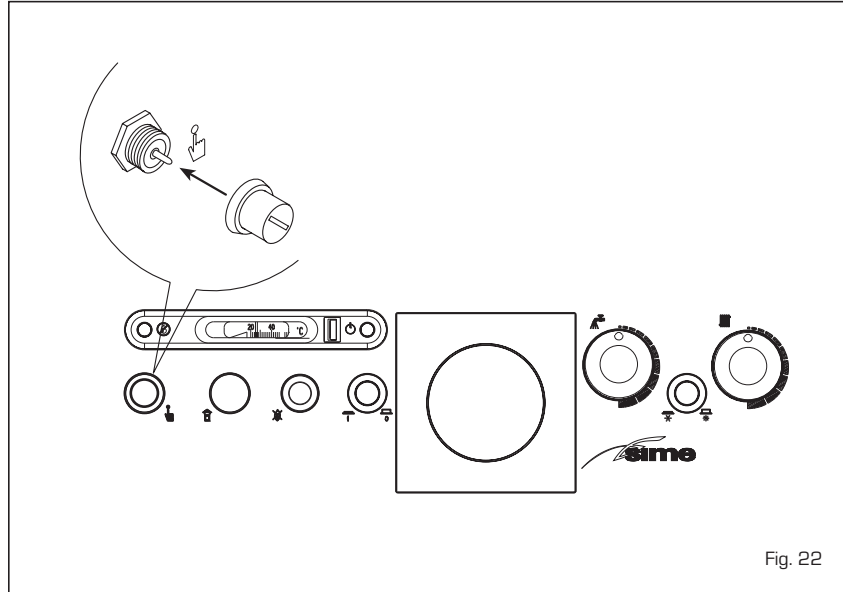

Fig. 22

**is advisable to interrupt the operation of the burner for about one hour.**

Close both the gas-feed pipe tap and the water tap if the boiler remains inoperative for a long period.

## TURNING OFF BOILER

It is sufficient to press the main switch to turn off the boiler (fig. 18).

## SYSTEM FILLING

Check periodically that the hydrometer

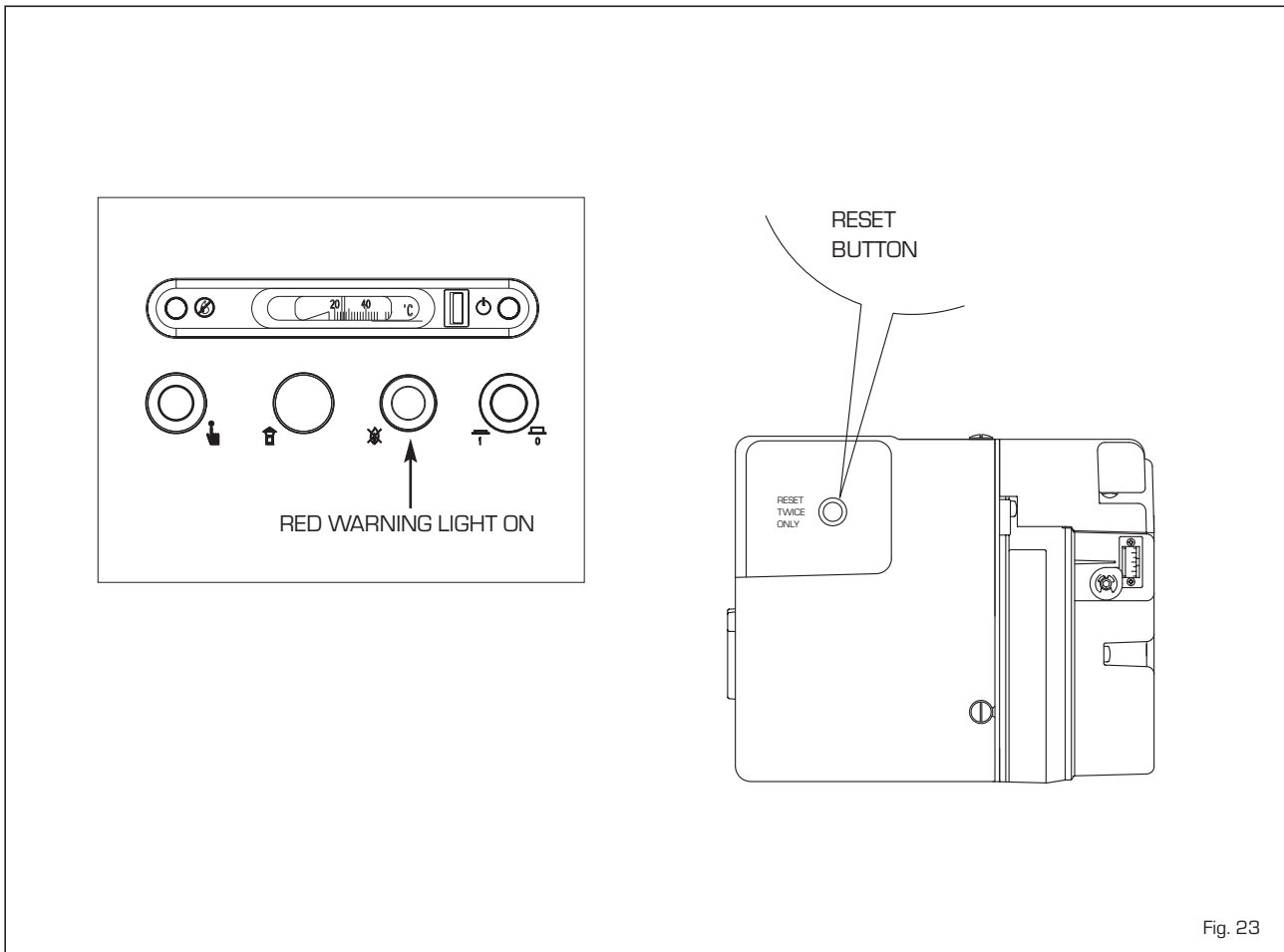

Fig. 23

has pressure values at a switched-off system of 1 - 1.2 bar.

If the orange water pressure gauge light turns on inhibiting boiler operations, restore operations by turning the supply tap counter-clockwise.

After the operation check that the tap is properly closed (fig. 24).

Should the pressure exceed the fore-

seen limit, discharge the superfluous amount by operating on the vent knob of any radiator.

#### CLEANING AND MAINTENANCE

At the end of each heating season, it is essential to have the boiler thoroughly

checked and cleaned out.

**Preventive maintenance and checking of the efficient operation of the equipment and safety devices must be carried out exclusively by the authorised technical staff.**

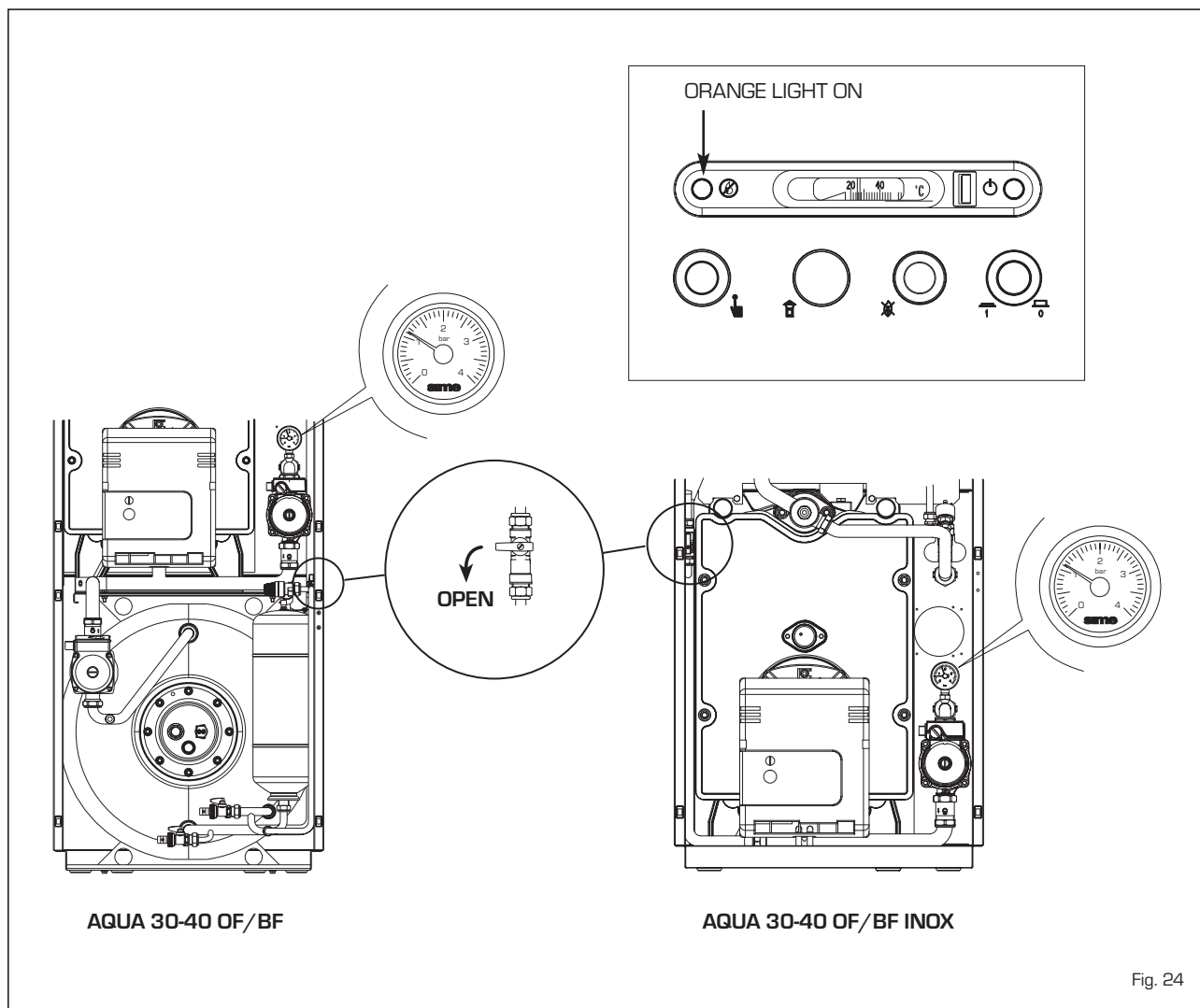

Fig. 24



## DICHIARAZIONE DI CONFORMITA' CALDAIE A COMBUSTIBILE LIQUIDO

La **FONDERIE SIME SpA**, con riferimento all'art. 5 DPR n°447 del 6/12/1991 "Regolamento di attuazione della legge 5 marzo 1990 n°46", dichiara che le proprie caldaie a combustibile liquido serie:

<b>AR</b>	<b>SOLO</b>	<b>RONDO' B</b>
<b>ARB</b>	<b>DUETTO</b>	<b>ESTELLE B</b>
<b>1R OF</b>	<b>AQUA</b>	<b>ESTELLE</b>
<b>2R OF/OF S/GT OF</b>	<b>RONDO'</b>	

sono complete di tutti gli organi di sicurezza e di controllo previsti dalle norme vigenti in materia e rispondono, per caratteristiche tecniche e funzionali, alle prescrizioni delle norme:

**UNI 7936** (dicembre 1979), FA130-84, FA168-87  
**EN 303-1994.**

Le caldaie a gasolio sono inoltre conformi alla **DIRETTIVA RENDIMENTI 92/42 CEE.**

La ghisa grigia utilizzata è del tipo EN-GJL 150 secondo la norma europea **UNI EN 1561.**

Il sistema qualità aziendale è certificato secondo la norma **UNI EN ISO 9001: 2000.**

Legnago, 5 settembre 2006

Il Direttore Generale  
ing. Aldo Gava









Fonderie Sime S.p.A  
Via Garbo, 27 - 37045 Legnago (Vr)  
Tel. + 39 0442 631111 - Fax +39 0442 631292  
[www.sime.it](http://www.sime.it)